

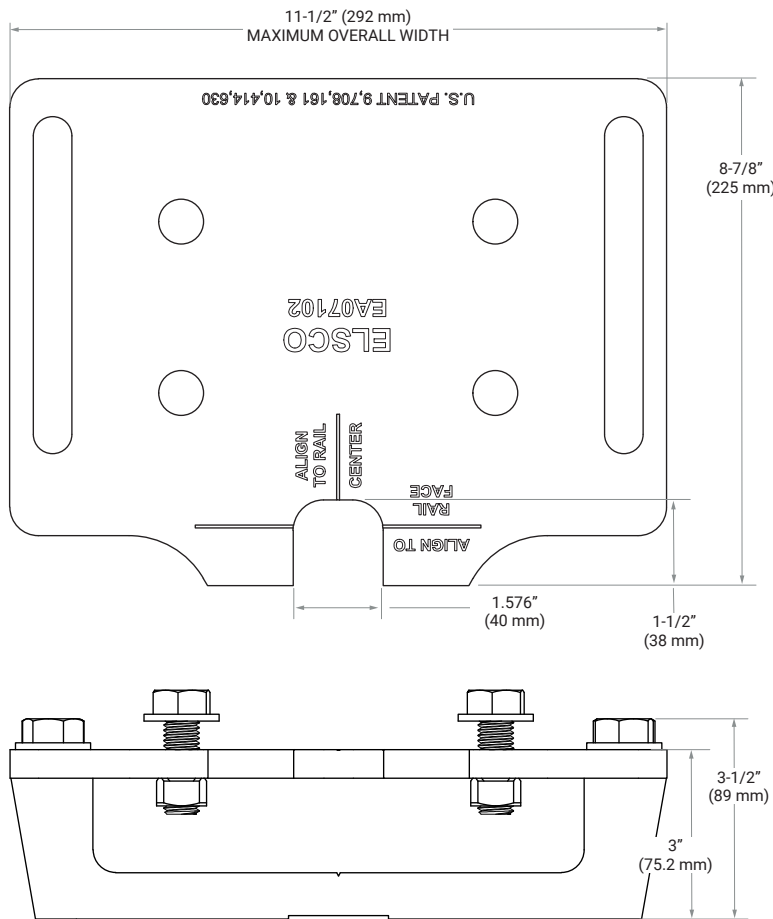

# FLEX-MOUNT™

## MOUNTING SPECIFICATIONS

Part Number EA07100



For use with Model A, Model B, Express-3, SA-15, SA-8  
 Use on balanced elevators with capacity up to: 10,000 lbs (4,536 kg)  
 Use on balanced counterweights with elevator load capacity up to: 10,000 lbs (4,536 kg)

Part Number EC07100

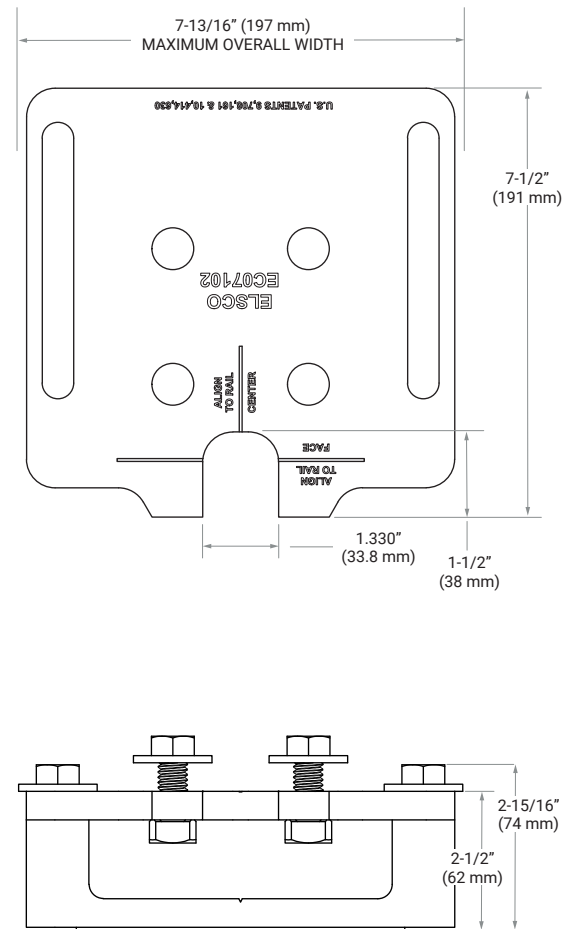

For use with Model C, Model D, SC-8, SD-8  
 Use on balanced counterweights with elevator load capacity up to:  
 > 10,000 lbs (4,536 kg) for most counterweights  
 > 3,500 lbs (1,588 kg) for applications with instantaneous safeties in EN zone  
 Use on balanced elevators with capacity up to:  
 > 3,500 lbs (2,722 kg) Class A loading only  
 > 2,000 lbs (900 kg) Class C1 loading only

## Make the install as smooth as the ride...

**Flex-Mount™** is an innovative, patented hardware kit designed specifically to allow ELSCO roller guides to mount on a range of pre-existing bolt patterns, without the need to take accurate measurements, create drawings, and fabricate custom adapter plates.

Suitable for use in seismic zones where the retention hardware is integrated into car or counterweight frame/safety gear.

## CAR FLEX-MOUNT™ INSTALLATION INSTRUCTIONS

Car Flex-Mount™ Adjustable Adapter Plates include:

- > 2 brackets
- > 1 plate
- > 8 bolts
- > 8 washers
- > 2 grooved dowel pins
- > 1 drill bit

Customer-supplied - required mounting hardware:

- > 4 x 5/8"-11 bolts, grade 8, zinc plated
- > 4 x 5/8" washers, grade 8, zinc plated
- > 4 x 5/8"-11 nuts, grade 8, zinc plated

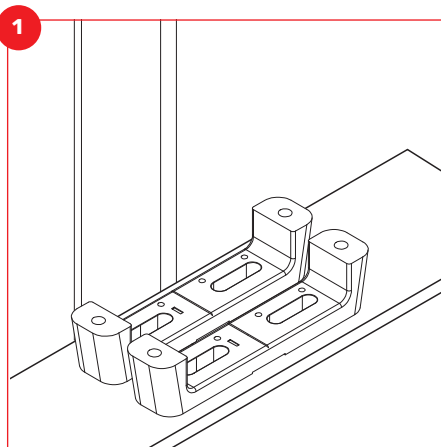

Clean mounting surface to remove any grease, debris, etc. Center elevator car. Position brackets onto mounting surface to confirm slots and mounting holes match.

If holes don't match, drill new 5/8" holes into mounting surface to line up with slots.

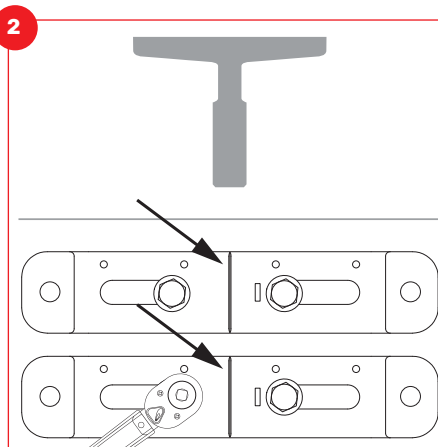

Place ASME-compliant mounting hardware (customer supplied) through slots and mounting surface. Align notches on brackets with center of face rail. Use torque wrench to tighten bolts to 160 ft-lbs to prevent slippage and hardware damage.

Balanced elevators with capacities less than 3,500 lbs do not require pinning. Proceed to step 5.

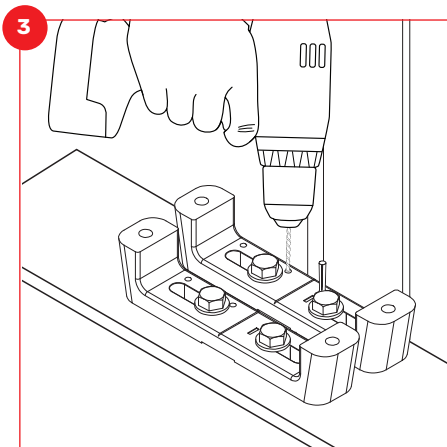

**For elevators with capacities greater than 3,500 lbs**

Use 1/4" drill bit to drill through two of provided holes in bracket closest to rail. Drill through bracket and at least 1/2" into mounting surface.

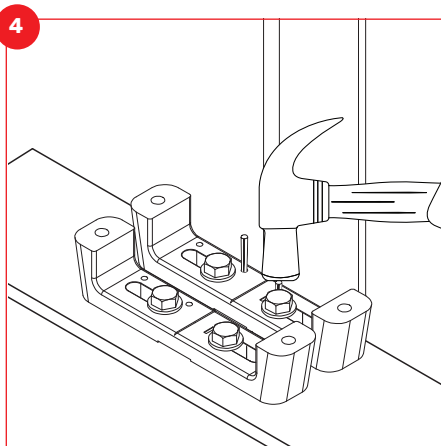

Using hammer, install narrow end of 1-1/4" tapered pins in newly-drilled holes (outer or inner holes only).

Top of pins should be close to flush with bracket after installation.

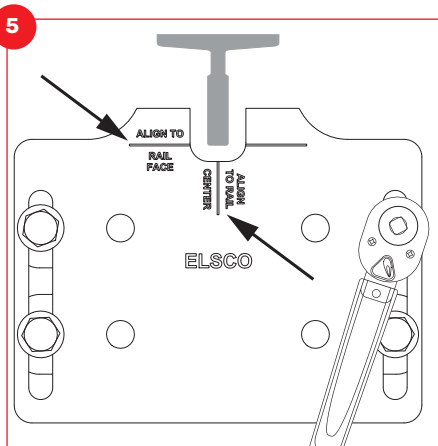

Position plate onto brackets and align notches on plate throat to rail. Use torque wrench to tighten provided bolts to 160 ft-lbs.

Continue with ELSCO guide installation. Use provided bolts and washers for that installation.

## COUNTERWEIGHT FLEX-MOUNT™ INSTALLATION INSTRUCTIONS

Counterweight Flex-Mount™ Adjustable Adapter Plates include:

- › 2 brackets
- › 1 plate
- › 8 bolts
- › 8 washers

Customer-supplied - required mounting hardware:

- › 4 x 1/2"-13 bolts, grade 8, zinc plated
- › 4 x 1/2" washers, grade 8, zinc plated
- › 4 x 1/2"-13 nuts, grade 8, zinc plated

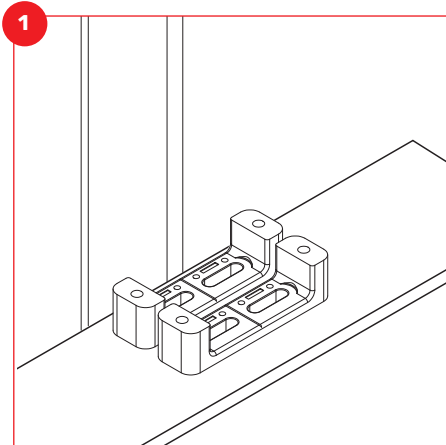

Clean mounting surface to remove any grease, debris, etc. Position brackets onto mounting surface to confirm slots and mounting holes match.

If holes don't match, drill new 1/2" holes into mounting surface to line up with slots.

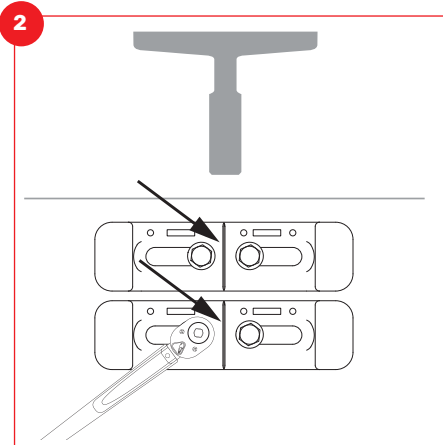

Place ASME-compliant mounting hardware (customer supplied) through slots and mounting surface. Align notches on brackets with center of face rail. Use torque wrench to tighten bolts to 80 ft-lbs to prevent slippage and hardware damage.

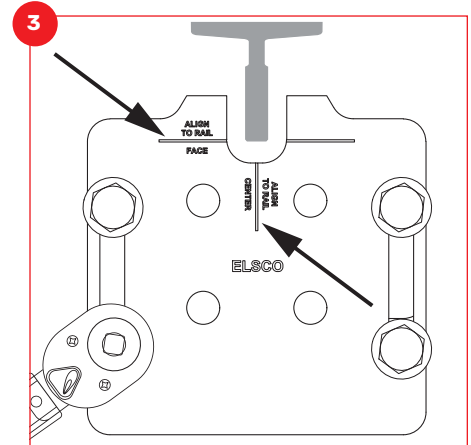

Position plate onto brackets and align notches on plate throat to rail. Use torque wrench to tighten provided bolts to 80 ft-lbs.

Continue with ELSCO guide installation. Use provided bolts and washers for that installation.

## RECOMMENDATIONS & SPECIAL CONDITIONS

### Car Flex-Mount™

- For Class B/C/C1/C2/C3, or significantly imbalanced elevators, contact ELSCO Customer Service to verify that Flex-Mount™ will withstand maximum loading of application

### Counterweight Flex-Mount™

- Contact ELSCO Customer Service if counterweight is significantly imbalanced or if rails are not aligned to center of frame

### Car & Counterweight Flex-Mount™

- Suitable for use in seismic zones where the retention hardware is integrated into car or counterweight frame/safety gear
- Elevator Safety Code Compliance:
  - › ASME A17.1-2013 (Compliant only for rails 5/8" and larger)
  - › EN 81-20, -50
- ASME-compliant when installed under these conditions:
  - › Existing mounting plate has no obstructions (i.e. bolt heads)
  - › Mounting hardware is ASME-compliant per specifications
  - › All hardware is properly torqued according to instructions

**FLEX-MOUNT™ SERVICE PARTS LIST**

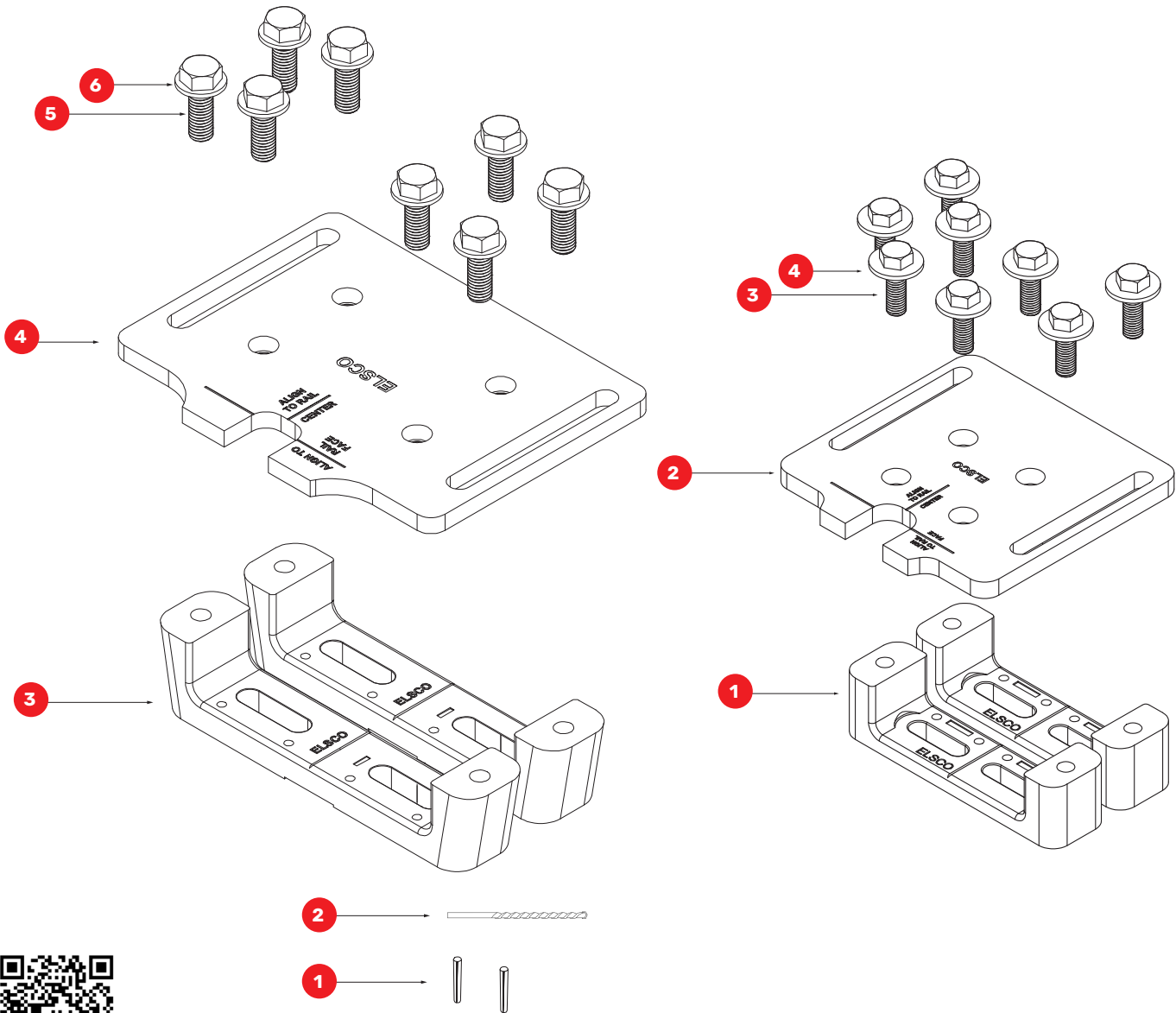

Scan here for more information.

**Flex-Mount™ Elevator Car Assembly**

KEY	QTY	PART #	DESCRIPTION
1	2	EA07110	1/4" Grooved Dowel Pin, 1-1/4" long
2	1	EA07113	1/4" Drill bit
3	2	EA07101	Bracket
4	1	EA07102	Plate
5	8	EA07103	5/8"-11 x 1-3/4" Bolt, Grade 8
6	8	EA07104	5/8" Washer, Grade 8

**Flex-Mount™ Elevator Counterweight Assembly**

KEY	QTY	PART #	DESCRIPTION
1	2	EC07101	Bracket
2	1	EC07102	Plate
3	8	EC07103	1/2"-13 x 1-1/2" Bolt, Grade 8
4	8	EC07104	1/2" Washer, Grade 8