

MODEL B

MODERATE SPEED ROLLER GUIDES

THE INDUSTRY STANDARD.

THE MODEL B ROLLER GUIDE OFFERS EXCEPTIONAL PERFORMANCE IN A COMPACT, EASY-TO-INSTALL PACKAGE. A BROAD APPLICATION RANGE, EASE OF USE, AND OUTSTANDING VALUE HAVE MADE THE MODEL B OUR MOST POPULAR ROLLER GUIDE.

FEATURES OF THE MODEL B GUIDE:

1. Neoprene Rubber Roller Wheels

are specially compounded and rigorously tested to ensure a smooth, silent ride. Only genuine ELSCO neoprene wheels provide the damping characteristics essential to ride quality, and only genuine ELSCO wheels are engineered with high "memory" characteristics that prevent flat spots. ELSCO rollers are precision ground to within .002 inches (.051mm) "Total Indicator Reading" for perfect roundness and concentricity, then 100% inspected under stress to ensure a secure bond between tire and hub.

2. Precision Ball Bearings guarantee years of silent use. ELSCO specifies bearings intended for the high RPMs and demanding loads of electric motors – conditions far more rigorous than typically seen in elevator applications. This means that even after years of operation and tens of millions of cycles, only ELSCO roller wheels remain completely silent. Each bearing bore is machined to a tolerance of five ten-thousandths (.0005) of an inch (.0127mm), and two bearings are pressed into each wheel by a computer-driven press, ensuring perfect fit and alignment.

3. Fully Adjustable Stabilizing Springs

allow the car to float between the rails, eliminating the bumps and vibrations that adversely affect ride quality.

4. Adjustable Stops enable precise control of the car's overall float between the rails, in both postwise and front-to-back axes. Adjustable stops are a standard feature on the Model B guide.

5. Durable Structural Components.

ELSCO castings are made from high-tensile-strength ductile iron and aluminum for an optimal combination of strength, durability, and light weight. High quality guide hardware ensures long life and ease of adjustment in the field. All components are inspected and assembled to exacting standards for a lifetime of reliable performance.

ELSCO roller guides and swivel sliding guide shoes offer a cost-effective approach for improving elevator ride quality by reducing the need for expensive, labor-oriented solutions and ongoing maintenance. That's why, to elevator contractors around the world, the ELSCO name is synonymous with quality and value. At ELSCO, We are ride quality.

Many factors must be considered when making a guide selection. Please call us to discuss your specific application.

◀ See inside for mounting instructions.

ELSCO

410.363.9020
info@elscoguides.com



A typical installation:
Passenger Elevator Cabin guides for
Low- to Mid-Rise Traction Elevator.
Speed: 350 fpm (1,75 m/s).
Capacity: 2,500 lbs. (1,100 kg).





ELSCO Model B elevator roller guides are designed with adjustment features that provide superior riding characteristics. The installer can easily adjust ELSCO guides to compensate for adverse operating conditions and to minimize noise, bumps and vibration. For optimum performance and longer roller wheel life, we recommend that elevator rails be properly aligned and cleaned, and the car balanced before operation.

ELSCO roller guides are carefully assembled, inspected, and packed to arrive in perfect condition. When your shipment arrives, inspect it carefully for damage and, if appropriate, immediately file a claim with the carrier. For best results, read all instructions thoroughly before proceeding with the installation.

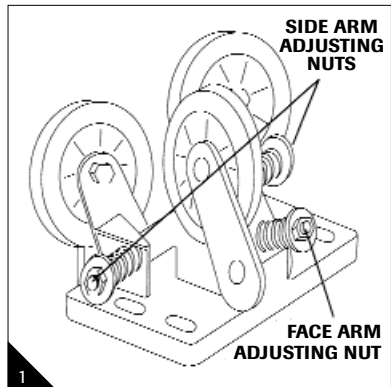

The Model B Guide comes completely assembled. **Note:** If adjustable stops have been ordered, they will be installed on the guide.

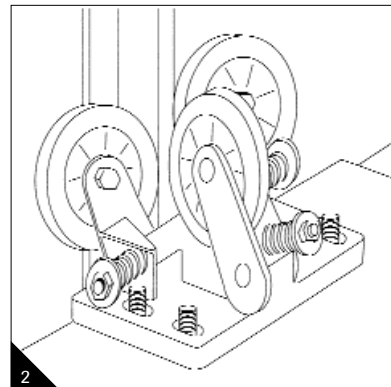

Position guide base over mounting holes or studs. Install mounting hardware (not included). Make certain that the center of the front mounting slots are located two inches (51mm) back from the face of the rail (refer to mounting template).

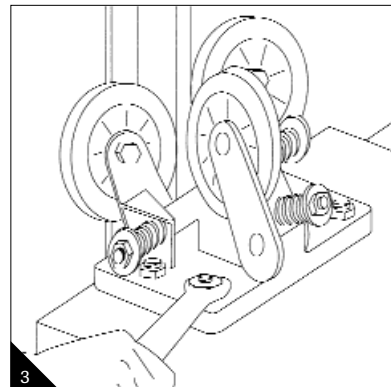

Securely tighten the mounting bolts and/or nuts. At this point, install the remaining roller guides on top and/or beneath the elevator.

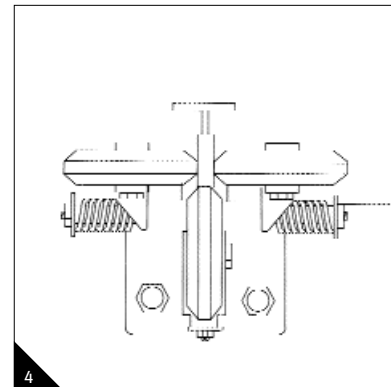

Be sure that guides are aligned properly (as shown) before making any further adjustments.

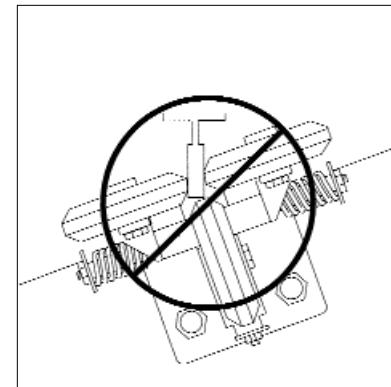

Improper alignment.

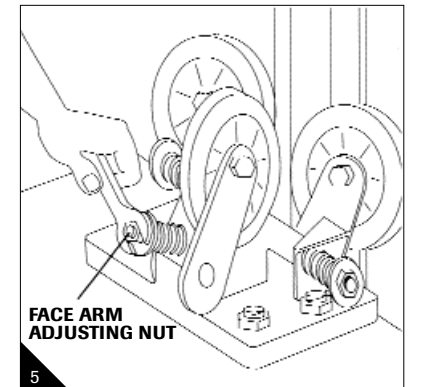

To adjust face roller wheel pressure, tighten face arm adjusting nut until the wheel is compressed $1/32"$ to $1/16"$ (1 to 2mm). This represents 25 to 50 lbs. (12 to 25kg) of wheel pressure. **Note:** If guides are equipped with polyurethane wheels, refer to step 11 for allowable wheel pressures.

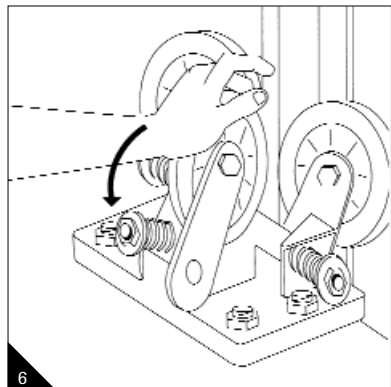

When properly adjusted, it will be possible to skid the face roller wheel by hand with moderate effort. Be certain that the face roller wheel pressures are equal for each guide.

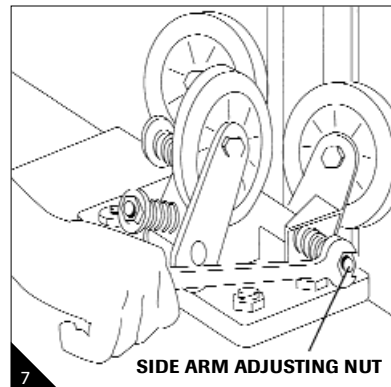

Adjust side roller wheel pressure. Turn the side arm adjusting nuts until side arm wheels are compressed $1/32"$ to $1/16"$ (1 to 2mm), and the face arm wheels are tracking in the center of rail. This represents approximately 25 to 50 lbs. (12 to 25kg) of wheel pressure on each side arm wheel.

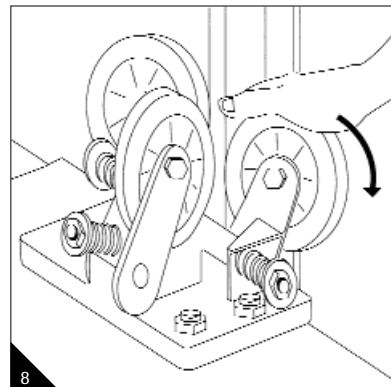

When properly adjusted, it will be possible to skid the side arm roller wheels by hand with moderate effort. **Note:** If guides are equipped with polyurethane wheels, refer to step 11 for allowable wheel pressures.

If guides are equipped with adjustable stops, refer to steps 9 and 10. Caution: Adjustable stops may shift during shipment. Be certain to position adjustable stops correctly (as shown in step 9 diagram).

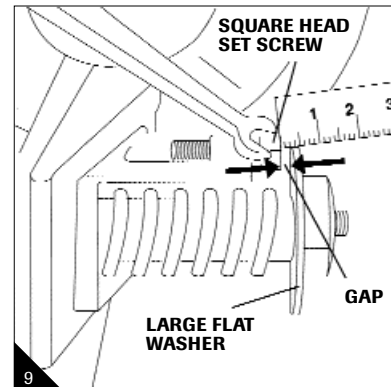

To adjust float, turn the square head set screw to increase or decrease the gap between the large flat washer and the head of the square head set screw. **Note:** The amount of float will be approximately twice the gap measured (e.g. $1/16"$ gap = $1/8"$ float, and 2mm gap = 4mm float).

10

Repeat step 9 for all three adjustable stops on each guide.

If installing guides equipped with polyurethane wheels, refer to step 11 for pertinent information.

11

ELSCO's polyurethane roller wheels are a hard (95 Shore A durometer) polymer material intended for use on lower speed elevators when the roller wheel pressures exceed those specified for neoprene composition wheels (25 to 50 lbs., or 12 to 25kg.)

While polyurethane roller wheels can operate at pressures up to 300 lbs. (140kg.) per wheel, it is advisable to keep static pressure as low as possible to prevent flat spots from forming while the elevator is sitting. Flat spots can adversely affect ride quality by causing a rough and/or noisy ride. At higher pressures, it may not be possible to skid the roller wheels by hand.

12

After all adjustments have been made, ride elevator in both the up and down direction at inspection speed to check hoistway clearances. Check to be sure that all mounting bolts and/or nuts are securely tightened. Make several more runs at operating speed, then recheck float (if applicable), tracking and roller wheel pressures before returning elevator to service.



TEMPLATE SHOWN ACTUAL SIZE

Model B
Mounting Template

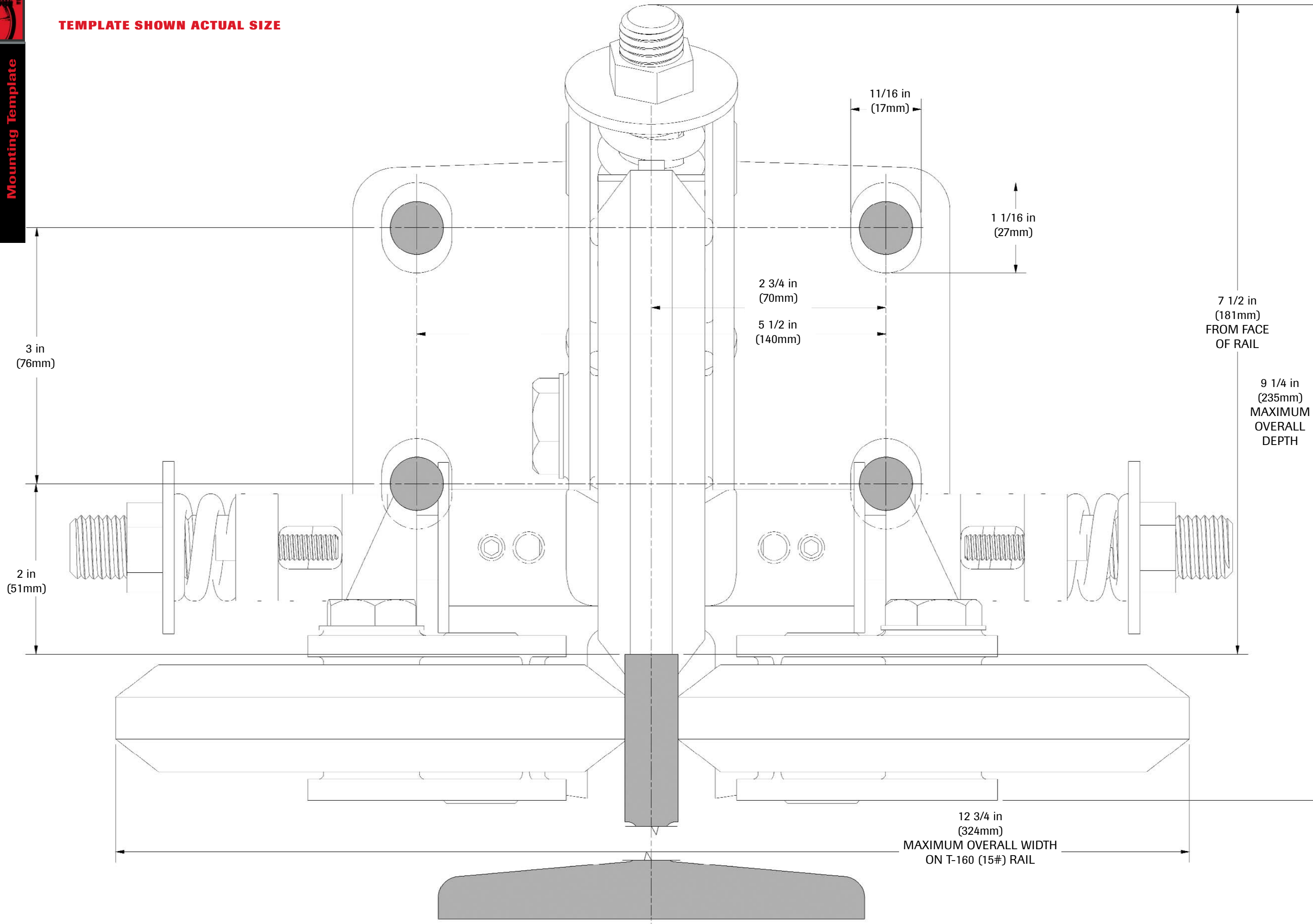



SPECIFICATIONS

Size and Weight

Height, Overall	9-3/4"	(248mm)
Width, Overall	12-3/4"	(324mm)
Depth, Overall Maximum	9-1/4"	(235mm)
Shipping Weight	31 lbs.	(14,1kg)

Mounting Bolt Holes

Four Slots..... 11/16" x 1-1/16" (17mm x 27mm)
 Bolt Hole Locations..... Refer to Mounting Template

Roller Wheels

Thickness.....	1-1/4"	(32mm)
Neoprene Tread Width (face & side arm roller wheel)	1/2"	(13mm)
Polyurethane Tread Width (face roller wheel)	1/2"	(13mm)
Polyurethane Tread Width (side arm roller wheel)	7/8"	(22mm)
Diameter	6"	(152mm)
Bearing I.D.	0.7874"	(20mm)
Runout (Total Indicator Reading)	0.002"	(.051mm)

Options and Factory Modifications Available

- Polyurethane composition roller wheels can be used to replace standard neoprene wheels in selected applications. Refer to the ELSCO guide selector chart or call an ELSCO guide specialist to determine proper applications. See our Frequently Asked Questions (FAQ) for more information about the trade-offs between neoprene and polyurethane wheel compositions.
- Cover plate kits are in stock and available for added safety and protection.
- Seismic retainer plates are available for select rail sizes. Call or e-mail for more information.

PARTS LIST

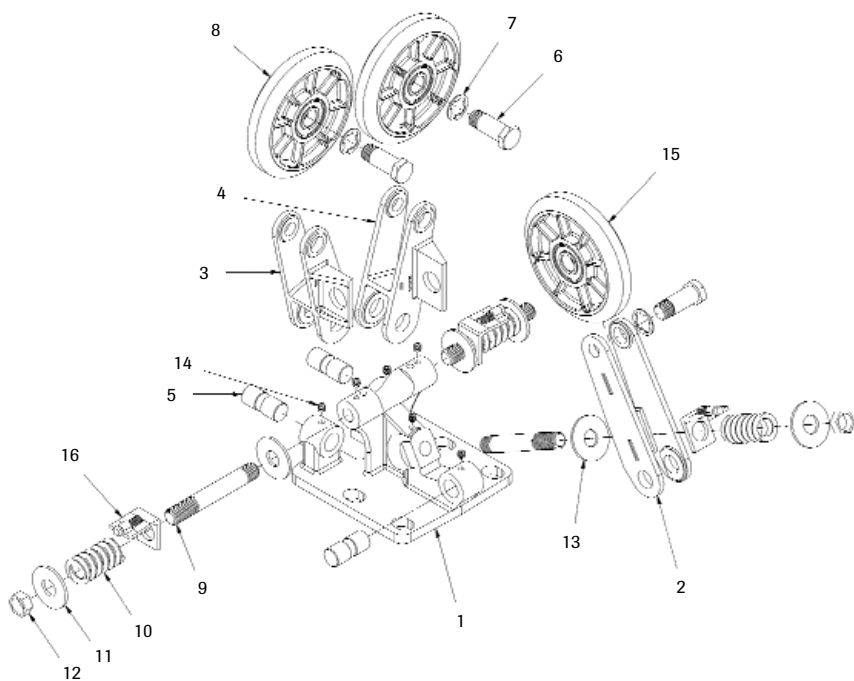

Model B Roller Guide

Key	Req.	Part #	Description
1	1	EB02101	Base
2	1	EB02104	Face Arm
3	1	EB02102	Left Side Arm
4	1	EB02103	Right Side Arm
5	3	EB02106	Pivot Pin
6	3	EB02105	Wheel Stud
7	3	EA18388	Wheel Stud Lock Washer
8	2	Rail Side Roller - See Roller Wheel Options Below	
9	3	EB02107	Side/Face Arm Stud
10	3	EA18379	Side/Face Arm Spring
11	3	EA18373	Flat Washer
12	3	EA18376	Locknut
13	3	EA18378	Rubber Washer
14	6	EA19765	Set Screw
15	1	Rail Face Roller - See Roller Wheel Options Below	
16	3	EB02119	Adjustable Stop

Standard Roller Wheel Configuration for Typical Installations:

12	4	■ EA18359	Standard Neoprene Roller Wheel Assembly, 6 in. (152mm)
21	2	■ EA18359	Standard Neoprene Roller Wheel Assembly, 6 in. (152mm)

Polyurethane Roller Wheel Configuration for Heavy-Duty Installations:

12	4	■ EA18347	Polyurethane Roller Wheel Assembly, 6 in. (152mm) - Rail Side
21	2	■ EA18348	Polyurethane Roller Wheel Assembly, 6 in. (152mm) - Rail Face

Notes:

Top Level Assembly for Model B Roller Guide with Std. Neoprene Rollers is EB02100.
 Top Level Assembly for Model B Roller Guide with Polyurethane Rollers is EB02114.

- Neoprene rollers are identical for rail side and face.
- Polyurethane rollers use different tread widths for rail side and rail face.