

MODEL A

H I G H S P E E D R O L L E R G U I D E S

THE FLAGSHIP

THE MODEL A ROLLER GUIDE HAS BEEN THE ELEVATOR INDUSTRY'S GOLD STANDARD FOR ELEVATOR RIDE QUALITY FOR OVER 45 YEARS. ITS OUTSTANDING PERFORMANCE, RUGGED DURABILITY, AND EXTENDED APPLICATION RANGE MAKE IT OUR FLAGSHIP PRODUCT.

FEATURES OF THE MODEL A GUIDE:

1. Six-Wheel Construction improves ride quality and extends the application range. The tandem roller design allows the guide to "step over" misaligned rail joints with only minimal disturbance to the cab and its occupants. And by using six wheels where most other guides use just three, the Model A can withstand the higher loads associated with service and hospital cars. The added stability also helps compensate for unbalanced conditions.

2. Neoprene Rubber Roller Wheels are specially compounded and rigorously tested to ensure a smooth, silent ride. Only genuine ELSCO neoprene wheels provide the damping characteristics essential to ride quality, and only genuine ELSCO wheels are engineered with high "memory" characteristics that prevent flat spots. ELSCO rollers are precision ground to within .002 inches (.051mm) "Total Indicator Reading" for perfect roundness and concentricity, then 100% inspected under stress to ensure a secure bond between tire and hub.

3. Precision Ball Bearings guarantee years of silent use. ELSCO specifies bearings intended for the high RPMs and demanding loads of electric motors – conditions far more rigorous than typically seen in elevator applications. This means that even after years of operation and tens of millions of cycles, only ELSCO roller wheels remain completely silent. Each bearing bore is machined to a tolerance of five ten-thousandths (.0005) of an inch (.127mm), and two bearings are pressed into each wheel by a computer-driven press, ensuring perfect fit and alignment.

4. Fully Adjustable Stabilizing Springs allow the car to float between the rails, eliminating the bumps and vibrations that adversely affect ride quality.

5. Adjustable Stops enable precise control of the car's overall postwise float between the rails. Adjustable stops are a standard feature on the Model A guide.

6. Durable Structural Components. ELSCO castings are made from high-tensile-strength ductile iron and aluminum for an optimal combination of strength, durability, and light weight. High quality guide hardware ensures long life and ease of adjustment in the field. All components are inspected and assembled to exacting standards for a lifetime of reliable performance.

ELSCO roller guides and swivel sliding guide shoes offer a cost-effective approach for improving elevator ride quality by reducing the need for expensive, labor-oriented solutions and ongoing maintenance. That's why, to elevator contractors around the world, the ELSCO name is synonymous with quality and value. At ELSCO, We are ride quality.

Many factors must be considered when making a guide selection. Please call us to discuss your specific application.

◀ See inside for mounting instructions.

ELSCO

410.363.9020
info@elscoguides.com

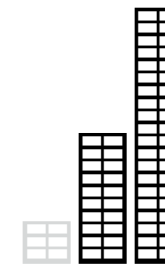
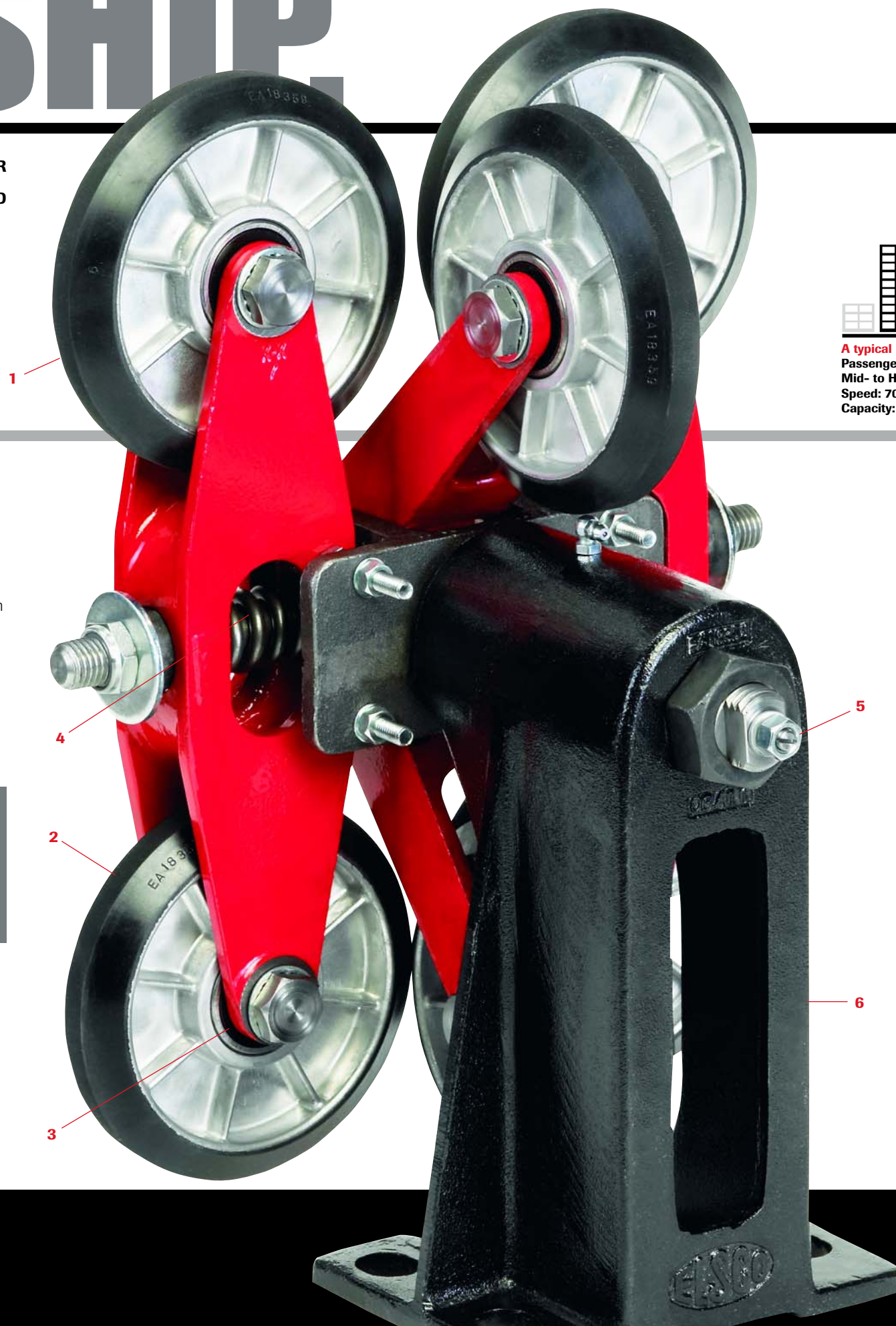

A typical installation:
Passenger Elevator Cabin guides for
Mid- to High-Rise Traction Elevator.
Speed: 700 fpm (3,5 m/s).
Capacity: 3,500 lbs. (1.600 kg).



ELSCO Model A elevator roller guides are designed with adjustment features that provide superior riding characteristics. The installer can easily adjust ELSCO guides to compensate for adverse operating conditions and to minimize noise, bumps and vibration. For optimum performance and longer roller wheel life, we recommend that elevator rails be properly aligned and cleaned, and the car balanced before operation.

ELSCO roller guides are carefully assembled, inspected, and packed to arrive in perfect condition. When your shipment arrives, inspect it carefully for damage and, if appropriate, immediately file a claim with the carrier. For best results, read all instructions thoroughly before proceeding with the installation.

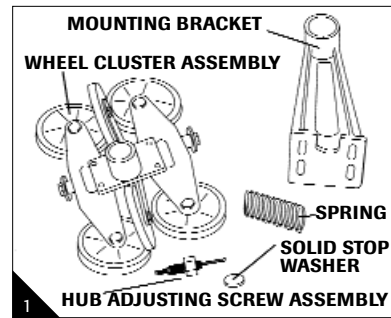

The Model A Guide includes: a mounting bracket, a wheel cluster assembly, and a bag containing a spring, a solid stop washer, and a hub adjusting screw assembly consisting of a hub adjusting screw with locknut, an adjustable stop shaft, lock washer and locknut.

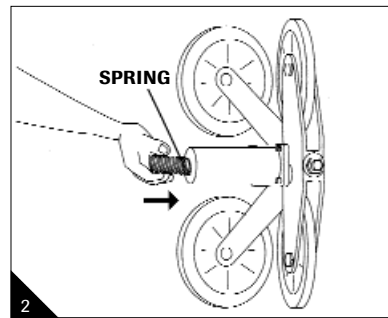

After verifying the proper location of the mounting holes (refer to mounting template), begin installation by inserting the solid stop washer into the hub. Now, insert the spring into the hub.

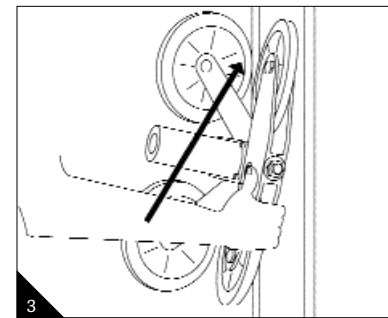

Position the uppermost roller wheels of wheel cluster assembly onto the rail, and while maintaining pressure against the rail, roll entire assembly upward until face roller wheels are firmly seated on the rail.

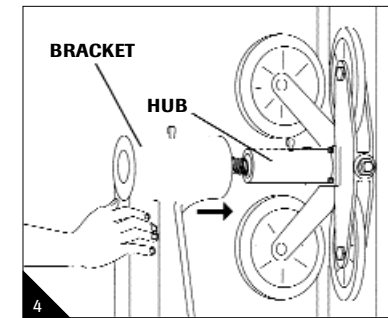

Place bracket onto the hub of wheel cluster assembly.

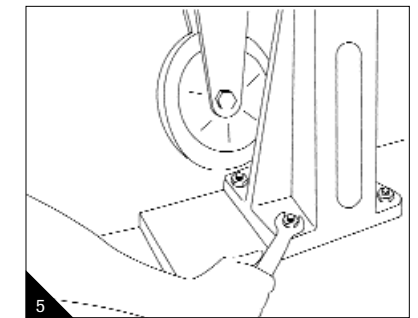

Position bracket over mounting holds or studs. Install mounting hardware (not included with guide) as required. Tighten lightly to hold bracket in place prior to final adjustment.

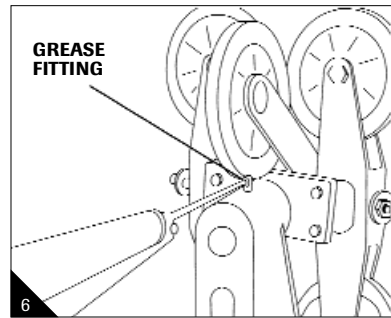

At this point, install the remaining roller guides on top and/or beneath the elevator. Lubricate the fitting on each guide with general purpose grease until a small amount appears between the hub and the bracket.

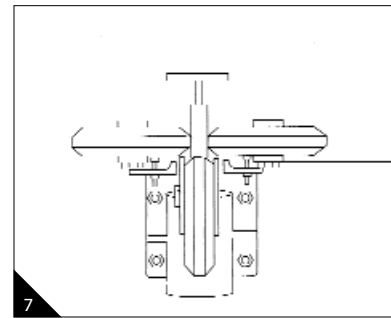

Be sure guides are aligned properly (as shown) before making any further adjustments.

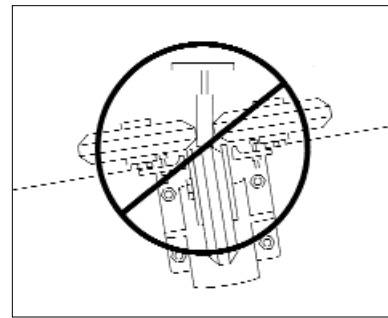

Improper alignment

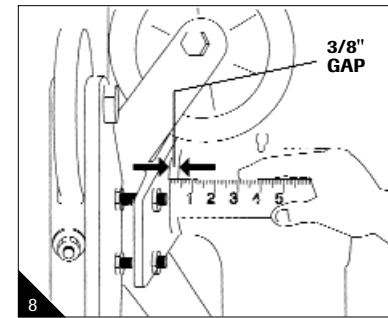

Set 3/8" (10 mm) gap between wheel cluster assembly and bracket. **Note:** Be certain that both face roller wheels are firmly seated against the rail while making this adjustment.

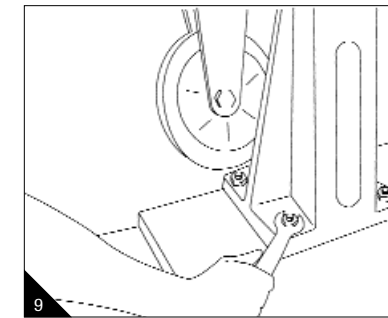

Securely tighten mounting bolts. Repeat steps 7 and 8 on remaining guides before proceeding. This helps assure that the elevator car will be properly centered between the rails.

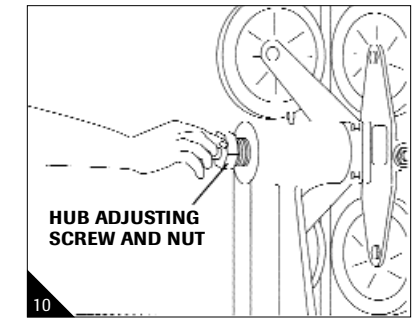

Install the hub adjusting screw assembly and nut into bracket. Adjustment of the large screw regulates the pressure of the face roller wheels against the rail.

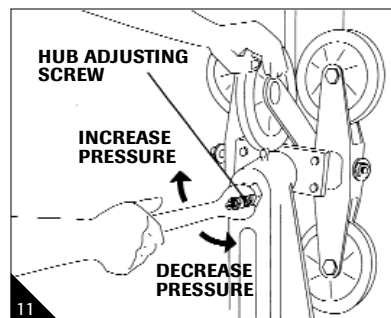

Turn the large hub adjusting screw until roller wheel tire is compressed 1/32" to 1/16" (1 to 2 mm) on the rail. This represents approximately 25 to 50 lbs. (12 to 25 kg) of wheel pressure. **Note:** If installing guides equipped with polyurethane roller wheels, refer to step 21 for allowable wheel pressures.

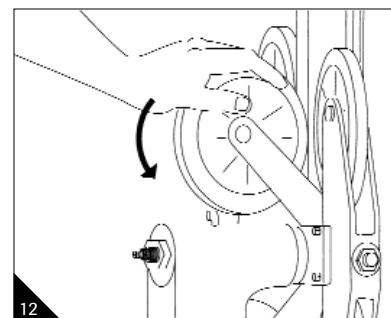

When properly adjusted, it will be possible to skid the face roller wheel by hand with moderate effort.

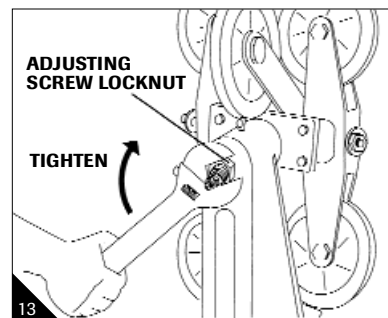

Be certain that both face roller wheel pressure and recommended gap measurement (see step 8) are equal for each guide. **Caution: This gap measurement may now be greater than 3/8" (10 mm), but should never exceed 1/2" (12 mm).** Now, tighten adjusting screw locknut.

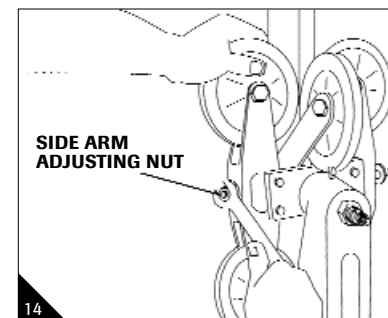

Adjust side arm roller wheel pressure. Turn side arm adjusting nuts until side roller wheels are compressed 1/32" to 1/16" (1 to 2 mm), and face wheels are tracking in the center of the rail. **Note:** If installation guides equipped with polyurethane wheels, refer to step 21 for allowable wheel pressures.

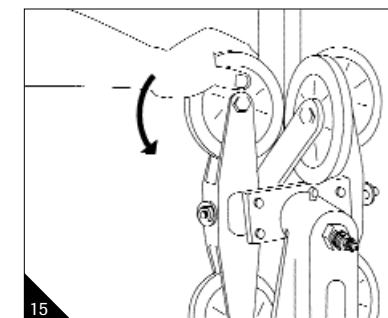

At this point, there will be 25 to 50 lbs. (12 to 25 kg) of pressure on each side roller wheel and the wheels can be skidded by hand on the rail with moderate effort.

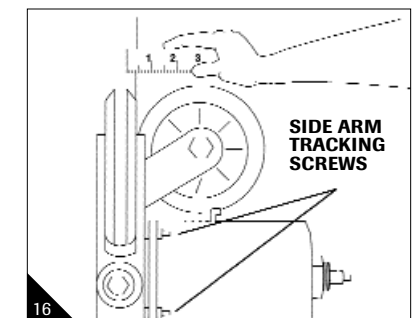

Each pair of side arm roller wheels should track parallel to the face of the rail. The distance from the edge of each roller wheel to the face edge of the rail should be the same at both the top and bottom wheels of each pair. **Note:** The side arm tracking screws are pre-set at the factory and should need no further adjustment.

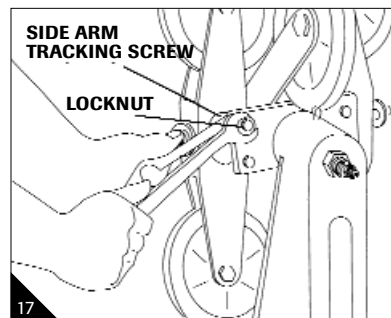

If it is necessary to adjust side arm tracking, loosen locknuts and turn side arm tracking screws until top and bottom roller wheels are parallel to the face of the rail. Now tighten locknuts. **Note:** If adjusted correctly, tracking screws should not restrict float or walking beam action of side arm assembly.



Repeat steps 14 through 17 for each remaining roller guide.

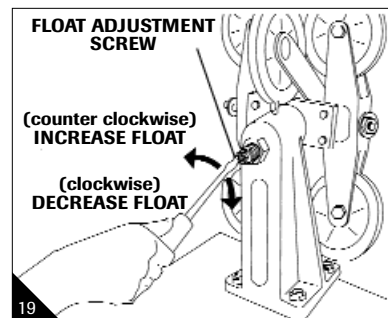

To set postwise float, turn adjustment screw clockwise until it makes contact with solid stop washer (installed in step 2). At this point, there will be zero postwise float. To increase float, turn adjustment screw counterclockwise. **Note:** Each full turn equals 1/16" (2 mm). For best results, set the float at 3/16" to 5/16" (6 mm to 10 mm).

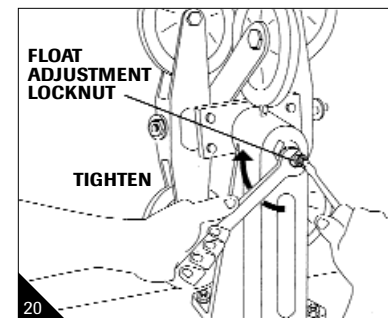

When the desired amount of postwise float is set, tighten locknut securely while holding float adjustment screw in place.

If installing guides equipped with polyurethane roller wheels, refer to step 21 for pertinent information.

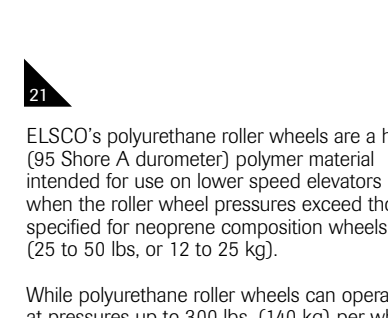

ELSCO's polyurethane roller wheels are a hard (95 Shore A durometer) polymer material intended for use on lower speed elevators when the roller wheel pressures exceed those specified for neoprene composition wheels (25 to 50 lbs, or 12 to 25 kg).

While polyurethane roller wheels can operate at pressures up to 300 lbs. (140 kg) per wheel, it is advisable to keep static pressure as low as possible to prevent flat spots from forming while the elevator is sitting. Flat spots can adversely affect ride quality by causing a rough and/or noisy ride. At higher pressures, it may not be possible to skid the roller wheels by hand.

After all adjustments have been made, ride elevator in both the up and down direction at inspection speed to check hoistway clearances. Check to be sure that all mounting bolts and/or nuts, and adjustment locknuts are securely tightened. Make several more runs at operating speed, then recheck float, tracking and roller wheel pressures before returning elevator to service.



Model A
Mounting Template

TEMPLATE SHOWN ACTUAL SIZE

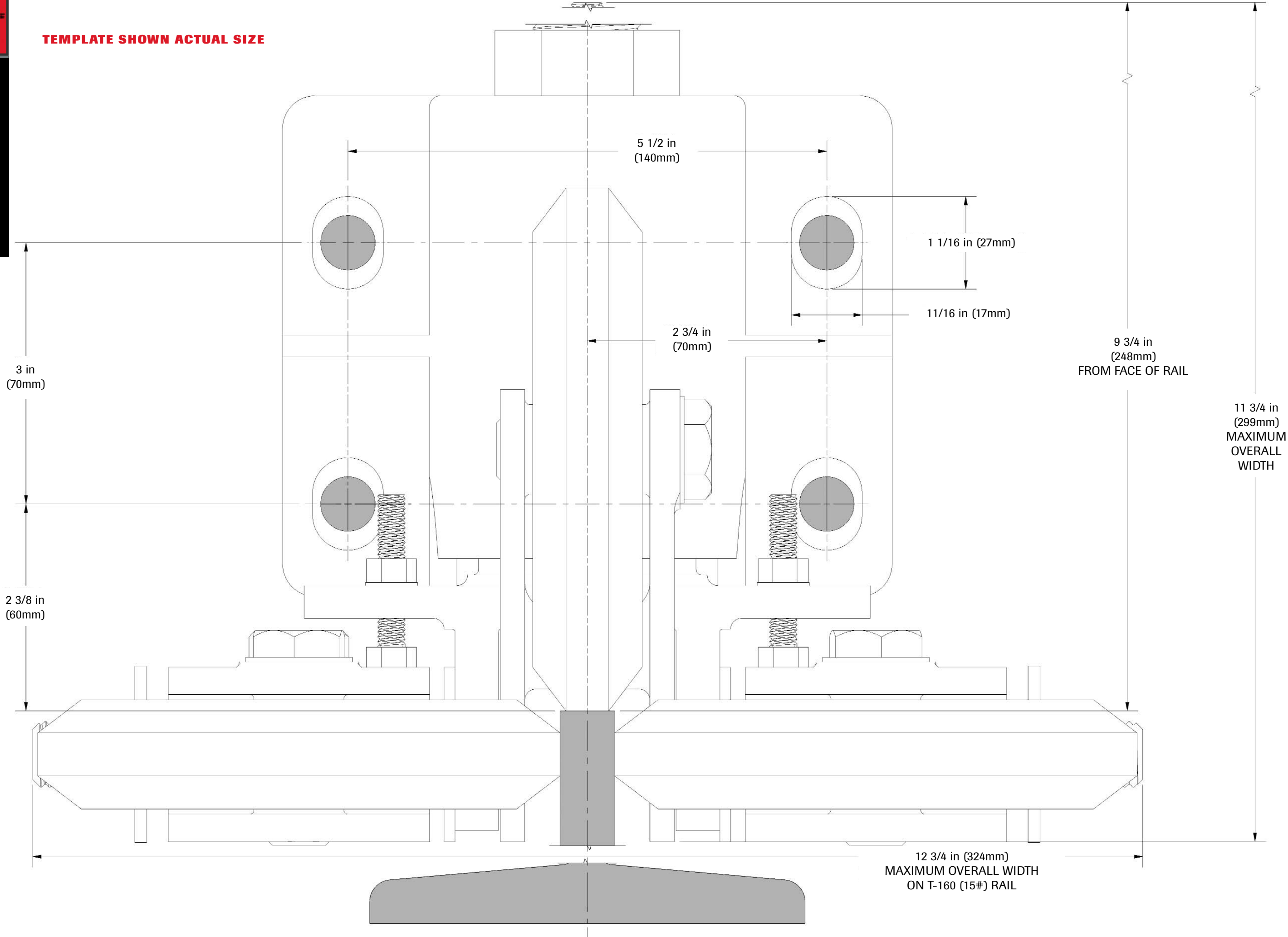



SPECIFICATIONS

Size and Weight

Height, Overall	18-1/2"	(470mm)
Width on 30 lb., 1-1/4" Rail	13-1/4"	(337mm)
Width on 15 lb., 5/8" Rail	12-5/8"	(321mm)
Depth, Overall Maximum	11-3/4"	(298mm)
Shipping Weight	61 lbs.	(27.7kg)

Mounting Bolt Holes

Four Slots	11/16" x 1-1/16"	(17mm x 27mm)
Bolt Hole Locations	Refer to Mounting Template	

Roller Wheels

Thickness	1-1/4"	(32mm)
Neoprene Tread Width (face & side arm roller wheel)	1/2"	(13mm)
Polyurethane Tread Width (face roller wheel)	1/2"	(13mm)
Polyurethane Tread Width (side arm roller wheel)	7/8"	(22mm)
Diameter	6"	(152mm)
Bearing I.D.	0.7874"	(20mm)
Runout (Total Indicator Reading)	0.002"	(.051mm)

Options and Factory Modifications Available

- Polyurethane composition roller wheels can be used to replace standard neoprene wheels in selected applications. Refer to the ELSCO guide selector chart or call an ELSCO guide specialist to determine proper applications. See our Frequently Asked Questions (FAQ) for more information about the trade-offs between neoprene and polyurethane wheel compositions.
- Cover plate kits are in stock and available for added safety and protection.
- Seismic retainer plates are available for select rail sizes. Call or e-mail for more information.

PARTS LIST

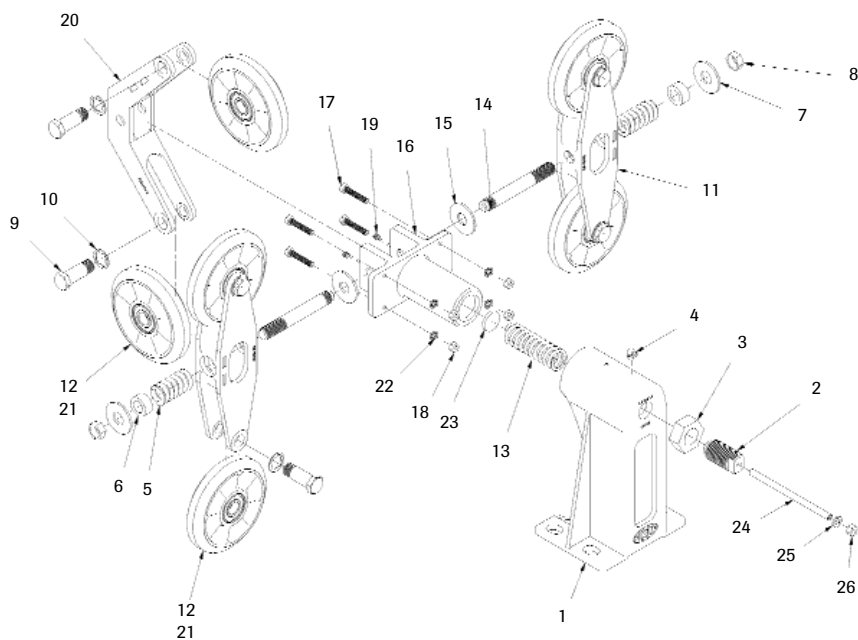

Model A Roller Guide

Key	Req.	Part #	Description
1	1	EA18354	Bracket
2	1	EA18327	Hub Adjustment Screw
3	1	EA19763	Hub Adjustment Locking Nut
4	1	EA18362	Grease Fitting
5	2	EA18379	Side Arm Spring
6	2	EA18307	Fiber Sleeve
7	2	EA18373	Flat Washer
8	2	EA18376	Locknut
9	6	EA18375	Wheel Stud
10	6	EA18388	Wheel Stud Lock Washer
11	2	EA18365	Side Arm
12	4	Rail Side Roller - See Roller Wheel Options Below	
13	1	EA18380	Hub Spring
14	2	EA18377	Side Arm Stud
15	2	EA18378	Rubber Washer
16	1	EA19727	Hub
17	4	EA19387	Side Arm Tracking Screw
18	4	EC18428	Hex Nut
19	2	EA19765	Set Screw
20	1	EA19729	Face Arm
21	2	Rail Face Roller - See Roller Wheel Options Below	
22	4	EF04131	Lock Washer
23	1	EA18328	Solid Stop Washer
24	1	EA18326	Adjustable Stop Adjustment Screw
25	1	EA18330	Lock Washer
26	1	EA18329	Nut
Standard Roller Wheel Configuration for Typical Installations:			
12	4	EA18359	Standard Neoprene Roller Wheel Assembly, 6 in. (152mm)
21	2	EA18359	Standard Neoprene Roller Wheel Assembly, 6 in. (152mm)
Polyurethane Roller Wheel Configuration for Heavy-Duty Installations:			
12	4	EA18347	Polyurethane Roller Wheel Assembly, 6 in. (152mm) - Rail Side
21	2	EA18348	Polyurethane Roller Wheel Assembly, 6 in. (152mm) - Rail Face

Notes:

- Top Level Assembly for Model A Roller Guide with Std. Neoprene Rollers is EA18300.
- Top Level Assembly for Model A Roller Guide with Polyurethane Rollers is EA18306.
- Parts can be ordered together as a kit under part no. EA18331.
- Parts cannot be ordered individually, and must be ordered as a complete subassembly.
- Neoprene rollers are identical for rail side and face.
- Polyurethane rollers use different tread widths for rail side and rail face.